

# Wireless Data Logger System



Process and Manage your Important Data Anytime from Anywhere

## RTR-5 Series

Temperature, Humidity,  
Voltage, Pulse, Event,  
Moisture



T&D's innovative RTR-5 Series consists of Compact Water Resistant Data Loggers, a Dedicated Base Station, Data Collector, and Communication Port which allows you to collect data and start/stop recording via wireless communication. Releasing you from the burden of physically gathering Data Loggers or wiring, this versatile series offers high-performance, high-capacity resources for data management.

T&D CORPORATION

# Wireless Data Logger

## Collect, Manage and Monitor Your Valuable Data via Wireless Communication

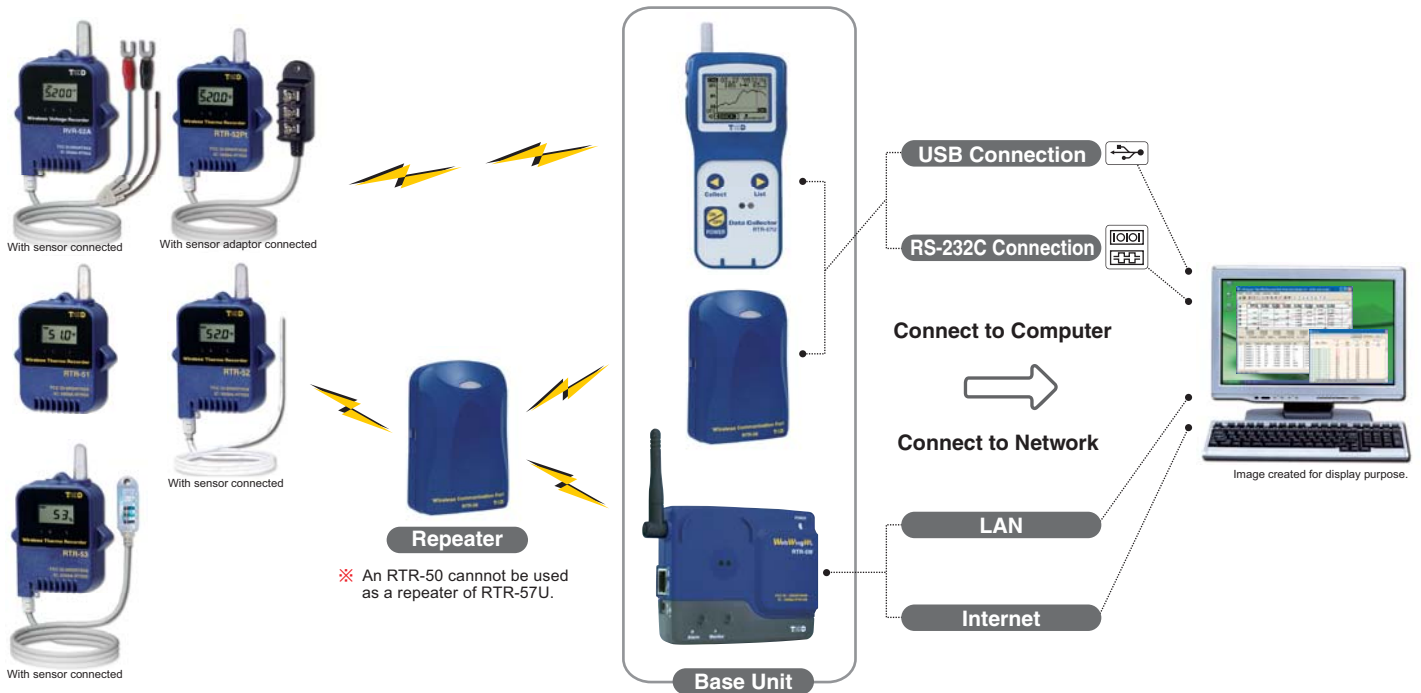

### Wireless Data Communication Function

Our RTR-51, 52, 52Pt, 53 and RVR-52A data loggers (Remote Units) can be used with each type of Base Unit (RTR-57U, RTR-5W, and RTR-50) to collect recorded data from the units via our exclusive short-wave technology. The wireless communication range, if unobstructed and direct, is about 100 meters (330 ft). Without physically gathering or going to the on-site Data Loggers, it is possible to collect data and make any necessary recording conditions settings and start recording.

**Note:** If collecting data via wireless communication, it is necessary to register via computer the RTR-51, 52, 52Pt, 53 and RVR-52A as Remote Units and the RTR-57U, RTR-5W, and/or RTR-50 as the Base Unit. Also, the data recorded by the Remote Units can be downloaded and other functions such as recording start settings can be made via optical communication by placing it on the RTR-57U, RTR-5W, and/or RTR-50 Unit.

### Transmission Range

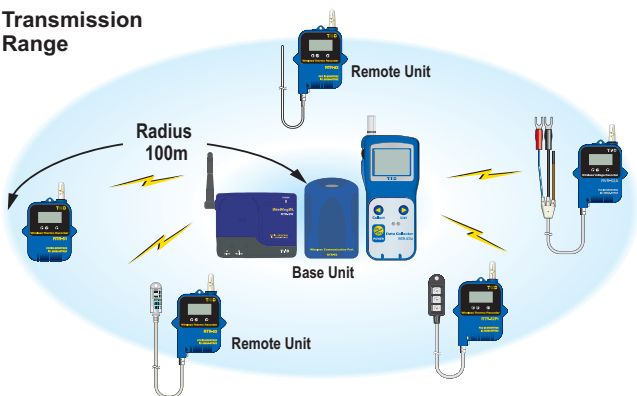

### Compact, Durable, Water Resistant

The lightweight yet durable water resistant construction allows you to use this unit under the harshest of conditions. It can be reliably used in high condensation areas, refrigerated and frozen environments as well as underground.

**Note:** The waterproofing is sufficient for most situations, but is not for continued immersion.

### Large Data Capacity: up to 16,000 Readings

With one unit you can record up to 16,000 readings. If set at a one hour recording interval that gives you 666 days or almost two years of readings. One RTR-53 can record up to 8,000 readings x 2 channels of measurement data. If an RVR-52A Unit is set to record event data, it can record up to 8,000 events.

### Register and Manage Remote Units by Groups

RTR-57U, RTR-5W, and RTR-50 are designed to manage any combination of RTR-51, 52, 52Pt, 53 and RVR-52A Units in groups. One RTR-57U Unit can be set up to manage up to 60 groups, with each group containing up to 64 units. If being set up via computer each RTR-57U can be set to handle 15 groups with each group containing 250 units. Using the RTR-5W, up to 64 Remote Units can be registered to one RTR-5W. One RTR-50 Unit can be set up to manage up to 250 groups, with each group containing up to 250 units. Multiple numbers of units can be divided into Groups for easy management.

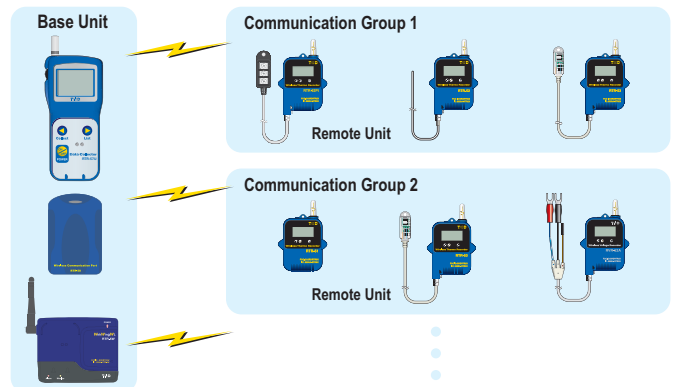

### Wireless Communication Possible in Range of -30°C to 80°C

Because wireless communication for all RTR-51, 52, 52Pt, 53 and RVR-52A Units can be made within the wide range of -30 to 80°C, it is possible to use the units to manage temperature in below freezing conditions such as frozen transportation and storage.

### Wide Selection of Recording Intervals / Two Recording Methods

The RTR-51, 52, 52Pt, 53 and RVR-52A give you 15 recording intervals (1 second to 1 hour) to choose from. Each unit allows you two choices of recording method:

#### One Time Method:

When 16,000 readings have been reached recording stops.

#### Endless Loop Method:

When 16,000 readings have been reached it automatically overwrites oldest data.

## Monitoring Function (RTR-57U)

It is possible to wirelessly monitor current readings, with the readings being sequentially displayed on the handheld RTR-57U Unit, without having to handle the Remote Units even when placed in a remote location. Moreover, by making upper and lower limit settings in the RTR-57U and/or Remote Units, if any of the set limits has been exceeded, a warning will be displayed and an alarm sounded. The interval between wireless communication sessions with the Remote Unit (monitoring intervals) can be set on the RTR-57U from 15, 30 seconds or from 1 to 60 minutes. If there is a multiple amount of Remote Units, the downloaded data is sequentially displayed on the handheld unit every 2 seconds.

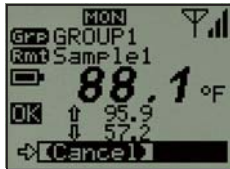

Image created for display purpose.

**Note:** Because new wireless communication will not be carried out until all current readings for all the Remote Units have been displayed, the monitoring interval may automatically be extended to longer than the set one.

## Wireless LAN via CF Card (RTR-5W)

The RTR-5W is designed with a CF card slot. By inserting a wireless LAN card in this slot, it is possible to connect a Wireless LAN; releasing you from the burden of cables and wiring.

**Note:** Please use only those CF type Wireless LAN cards that have been proven to be compatible and are for suggested use. For details, contact your local representative or dealer.

## Monitoring Current Readings on Computer Display (RTR-50)

With our exclusive software, you cannot only monitor the current measurements, but can view those measurements in a continually changing graph on your computer display. Moreover, it is possible to simultaneously view the current measurements of multiple Remote Units in one browser.

## Exclusive Software Provided (RTR-57U/RTR-5W/RTR-50)

User friendly yet high-performance software is included with each RTR-57U, RTR-5W, and RTR-50. The easy-to-use software allows you to control various aspects of operations such as printing, creating text files, tables and colorful graphs of the recorded data in the Remote Units. For details about the software functions, see p.6,7.

## Special Circuitry for Long Battery Life

Using our specially designed low energy consumption circuit this unit can run on one lithium battery for up to six months of continued use. In addition, by using our specially designed optional large capacity battery pack, the unit can be used continuously for up to two and a half years. No need to worry about where you place it, as the battery will allow you to measure and record over long periods of time whether the unit is in transit or in a distant place.



With Large Capacity Battery attached

**Note:** Battery life will depend on the recording environment, recording interval, communication frequency, and ambient temperature. The above battery life test was carried out using brand new batteries and in no way do we guarantee a battery's life. Removing the battery and not replacing it will result in a loss of all recorded data.

## Monitoring Current Readings, Viewing Data in Graph via Browser (RTR-5W)

The RTR-5W is able to gather via wireless communication the measured and recorded data from any RTR-5 Series Data Logger and using a Local Area Network (LAN) or Internet connection makes it possible to view current readings and/or download the gathered recorded data. Via the browser it is possible to monitor the current readings of any Remote Unit that has been registered and view the current readings collected at fixed interval in a simplified graph form.



Monitor Current Readings Window

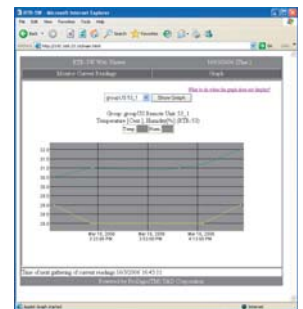

Graph Window

# System Setup

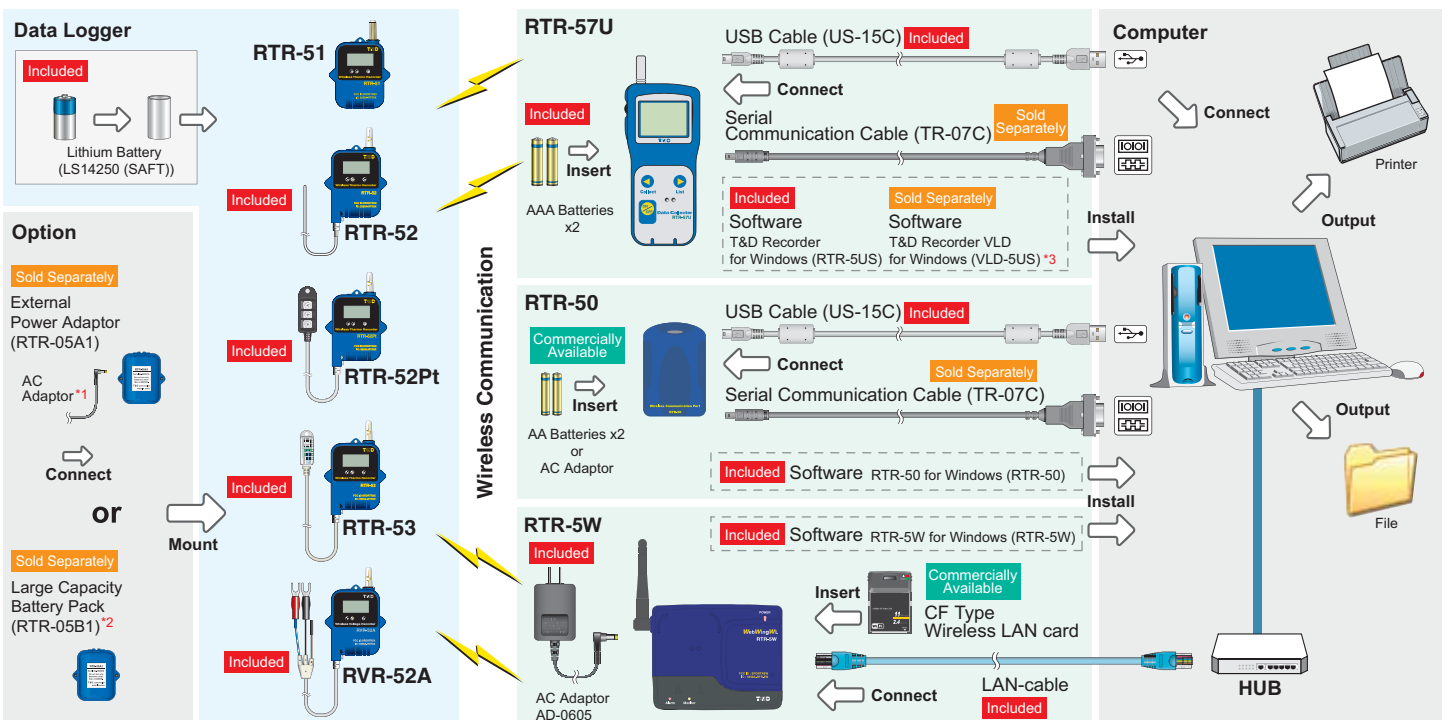

\*1: When using RTR-05A1, it is necessary to purchase AC Adaptor. \*2: When using RTR-05B1, it is necessary to purchase Lithium Battery (LS26500). \*3: T&D Recorder VLD for Windows (VLD-5US) is optional software. For details, contact your local representative or dealer.

# Thermo Recorder

# Temperature/Humidity Recorder



RTR-51 / 51L

RTR-52 / 52L  
With sensor connected



RTR-52Pt / 52PtL  
With sensor adaptor connected

RTR-53 / 53L  
With sensor connected

## Temperature Recording Range:

**-40 to 80°C (RTR-51), -60 to 155°C (RTR-52)**

The RTR-51, with internal sensor, can measure and record temperatures from -40 to 80°C and the RTR-52, with external sensor, is able to measure and record in a range of -60 to 155°C.

**Note:** The main unit is designed for use in environments with an ambient temperature of -40 to 80°C, but in an environment with a temperature of below -30°C wireless communication will not be possible.

## Temperature Recording Range:

**-199.9 to 600°C (RTR-52Pt)**

Designed to be used with a three-wire Pt100 / Pt1000 Temperature Sensor, the RTR-52Pt enables users to measure and record temperature in the range of -199.9 to 600°C. The RTR-52Pt greatly enhances the measurement range performance and increases the application possibilities of our RTR-5 Logger Series.

**Note:** Designed for easy compatibility, the RTR-52Pt can be used with any three-wire type Pt100 / Pt1000 temperature sensor. For information concerning which types of Pt100 temperature sensors T&D is releasing, please see our Website. The main unit is designed for use in environments with an ambient temperature of between -40 to 80°C, but in an environment with a temperature of below -30°C wireless communication will not be possible.

## Humidity Recording Range:

**10 to 95%RH (RTR-53)**

The RTR-53 with its temperature/humidity sensor is able to simultaneously measure and record temperature within a range of 0 to 55°C and humidity within a range of 10 to 95%RH.

The sensor for the RTR-53 has been specially designed to withstand certain amounts of condensation.

**Note:** The main unit is designed for use in environments with an ambient temperature between -40 to 80°C and is water resistant, but in an environment with a temperature of below -30°C wireless communication will not be possible.

# Voltage Recorder

# Voltage/Pulse/Soil Moisture Recorder



RVR-52A / 52AL  
With cable connected



ECHO(CE-20)  
Voltage output proportional to water content.

## Soil Moisture Measurement

It is possible to measure soil moisture using Decagon Devices Inc, Soil Moisture Sensor ECHO Probes (EC-10, EC-20). The RVR-52A has a built-in excitation voltage (2.5V) for the ECHO probe that allows for easy direct connection. The output from the ECHO probe is converted directly into moisture volume content by percentage (%) and displayed as such. Moreover, by using the adjustment function in the accompanying software [T&D Recorder for Windows (RTR-5 US)] you can achieve even more accurate readings.

**Note:** T&D Corporation does not handle or sell the Soil Moisture Sensors ECHO Probe (EC-10, EC-20). All inquiries and questions concerning sales of and the operational specifications of the sensors should be made to Decagon Devices Inc. [<http://www.decagon.com>]

## Built-in Pre-heat Function

The RVR-52A includes an internal pre-heat function which sends signals to turn ON / OFF external sensors, etc...in time with the starting of recording.

## Event Time Recording

RVR-52A can record the time of any event; a rising (Lo to Hi) or falling (Hi to Lo) waveform that occurs for more than 1 second at an input voltage range of between 0-30V.

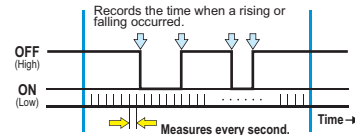

## Pulse Measurement: 30 Counts per Second

RVR-52A can measure up to 30 counts (30Hz) per second when the input voltage range is between 0-30V and there is a continuous pulse of more than 15 msec. When measuring pulse, the largest number of counts for one recording interval is 32,000 counts. You can select from rising signal (Lo-Hi) or falling signal (Hi-Lo) for counting.

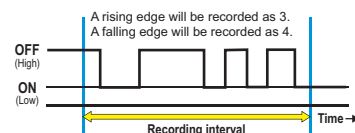

## Voltage Measurement Range: 0 to 6.5V

RVR-52A can measure and record input voltage from 0 to 6.5V. You can choose to record the voltage measurement as the instantaneous value for each recording interval span or as the average value for each recording interval span. The average value for recording intervals under 15 seconds, will be calculated as the average of the measurements from every 1 second. The average for intervals over 20 seconds will be calculated as the average of the measurements from every 2 seconds.

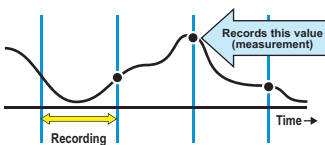

**Recording by Instantaneous Value**  
Records measurements at set recording interval

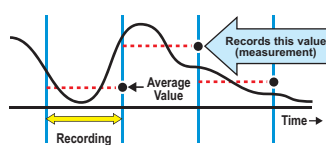

**Recording by Average Value**  
Records the average value of the measurements taken every second (or every two seconds) within the set recording interval.



## Multiple Repeaters Greatly Extend Wireless Communication Range

By setting up one or, if necessary, multiple RTR-50 Unit(s) between the Base Unit and Remote Unit(s), it is possible to extend the wireless communication range and route wireless communication from the Base Unit to the Remote Unit(s). Up to 250 Repeaters can be set up.

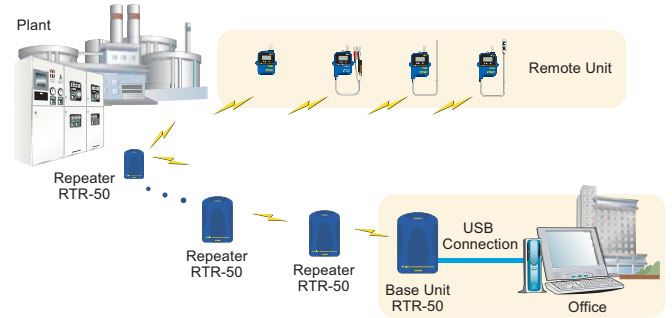

\*The Communication Range for a RTR-50 Repeater is up to 100m.

## Use as a Base Unit or Repeater

Our multipurpose Wireless Communication Port RTR-50 has been designed to be used in two ways: as a Base Unit for the wireless downloading of recorded data from RTR-5 Series Data Loggers (RTR-51/52/52Pt/53/RVR-52A) or to help broaden the range of wireless communication, they can be set up to use as a Repeater between a Base Unit and the Data Loggers.

## Send Warning Report E-Mails when a Warning Occurs

Warning Monitoring can be carried out at each location and if any of the gathered data exceeds the set limit, by making warning mail settings, a notification can be sent to the specified address(es) via E-mail. A warning report E-mail can be sent to up to 50 mail addresses.

**Note:** Warning Report Mail Send function cannot be used with Windows 98SE.

## Auto-Download via Wireless Communication

With an RTR-50 connected to your PC, it is possible to automatically download recorded data from Remote Units via wireless communication. Data can be downloaded from a Remote Unit or Group of Remote Units at a certain time every day or at a set interval. Take advantage of this function and never miss downloading data again.

# RTR-50 for Windows

The simple yet powerful software, "RTR-50 for Windows" offers a variety of useful functions for RTR-5 Series Data Loggers (RTR-51/52/52Pt/53/RVR-52A), including recording settings, data downloading, graph display, table creation, printing, and file output.

## Effectively Manage Registration, Settings, and Communication

Up to 250 Remote Units can be easily registered and necessary settings changes can be performed in a snap.

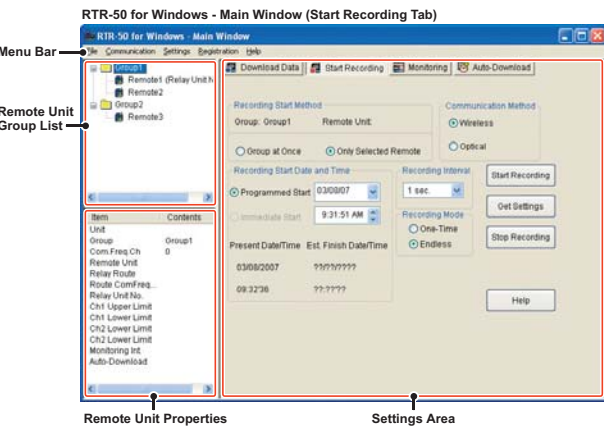

## Software Included with RTR-50

### Easy and Intuitive Operation

Our user-friendly software gives you a quick, easy, and intuitive way to operate Unit Registration (Connection) via your computer display. By simply dragging and dropping the registered Remote Unit to the newly desired location, it is possible to change the communication route easily.

Connect a Remote Unit via Repeater

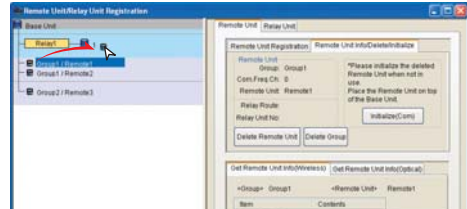

### Event Viewer

View event data recorded by RVR-52A in table form. You can further view info about the data in the viewer or print it out.

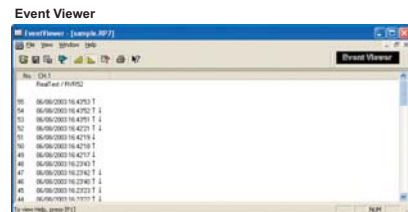

## Array of Versatile Functions

Using this software, you can perform various tasks for data management such as the Monitoring of Current Readings and Warning Monitoring (Send Warning E-mail), as well as Auto-Download. In addition, our exclusive software allows you to easily process the data into graphs, tables, save to files and/or print it out.

Monitoring Graph Window

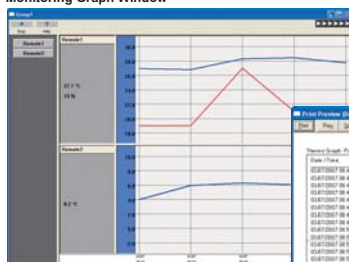

Print Preview Window

## Interpret Data in Graphs and Tables

Recorded data can be displayed in colorful easy to interpret graphs and tables and analyzed by using Temperature / Humidity Graph and Multi-Scale Graph. Full use of the Windows interface makes the operation simple yet dramatic.

Multi-scale Graph

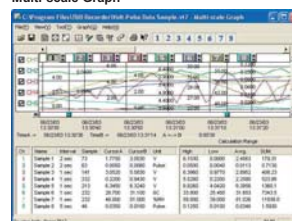

Data List

# Data Collector

# Handheld Data Collector RTR-57U

## Easy-to-Read LCD Graph Display



The RTR-57U gives you a high quality graph display of collected data. Each graph displays the data for one channel and can be easily scrolled across by using the handy operation dial or the buttons on the front of the main unit. This function gives you the data you want in an easy-to-understand format.

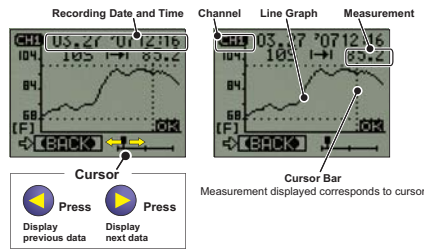

## Data Capacity: 256,000 Readings

The data capacity for the RTR-57U is 256,000 readings. That is a large enough capacity to collect data from 16 units of RTR-51,52,52Pt,53 or RVR-52A at full capacity (16,000 readings). Moreover, it can collect and manage up to 250 separate data recording sessions.

## Easy Data Collection from a Variety of Units

The RTR-57U can collect data from any RTR-5 Series, RVR-52A and VR-71 Logger, as well as, from any TR-5 or TR-7 Series Unit (excluding TR-73U). Data downloading can be carried out via wireless communication with any RTR-5 Series and RVR-52A Unit or by simply placing it front down on the communication pad area as done with any TR-5 Series Unit. Data from other types of units can be downloaded via the provided communication cable connection.

## Monitor Measurements while Downloading

By making upper and lower limit settings on the RTR-57U you can monitor the recorded data as it is collected for irregularities and the results will be displayed. If any RTR-51,52,52Pt,53 or RVR-52A Unit has already been set with its own upper and/or lower limit, those values will take precedence over the values set in the RTR-57U.

## Manage Recording Settings No Computer Necessary

Besides controlling the collection of data, the RTR-57U can manage various recording settings such as: Recording Mode, Recording Interval, Programmed/Immediate Recording Settings. This enables the user to easily control various recording settings for a variety of models on-site without the need for a computer.

# T&D Recorder for Windows (RTR-5 US) Software Included with RTR-57U

Easy-to-use Windows software allows you to control all aspects of set up, recording and downloading as well as printing, creating text files, tables and colorful graphs of the recorded data.

## Up to 8 Channels of Data in One Graph

Up to eight channels of temperature and humidity data can be simultaneously viewed in one Temp/Humidity Graph and up to eight channels of voltage, pulse, temperature and humidity data can be viewed in one Multi-scale Graph. Moreover, you can easily hide and view channels, make changes to graph colors and zoom-in and -out on data with the click of a mouse. Color printing of the graph, as you see it on display, is also possible.

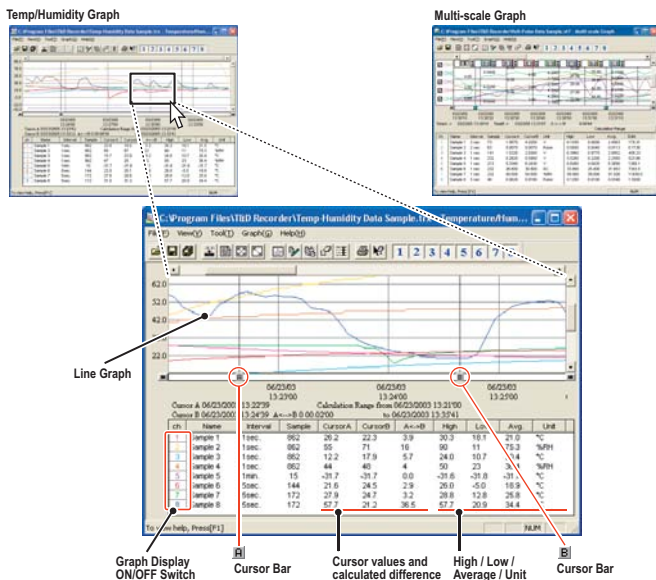

## Event Viewer

View event data recorded by RVR-52A in table form. You can further view info about the data in the viewer or print it out.

No.	CH 1	CH 2
89	23/05/2003 16:51:05 T	23/05/2003 16:51:33 T
90	23/05/2003 16:51:04 T	23/05/2003 16:50:57 T
97	23/05/2003 16:51:03 T	23/05/2003 16:50:25 T
96	23/05/2003 16:51:02 T	23/05/2003 16:50:24 T
95	23/05/2003 16:51:01 T	23/05/2003 16:50:23 T
94	23/05/2003 16:51:00 T	23/05/2003 16:50:22 T
93	23/05/2003 16:50:59 T	23/05/2003 16:50:21 T
92	23/05/2003 16:50:58 T	23/05/2003 16:50:20 T
91	23/05/2003 16:50:57 T	23/05/2003 16:50:19 T

## Display Data in Table Form

The data in the graph can be viewed in table form with the High in red, the Low in blue and the Average in pink. You can print all of the data in the list or select and print only those pages you desire.

Date / Time	Sample 1	Sample 2	Sample 3	Sample 4	Sample 5
05/23/2003 13:21:10	30.3	11	11.0	35	
05/23/2003 13:21:11	30.3	13	11.0	35	
05/23/2003 13:21:12	30.3	13	10.9	35	
05/23/2003 13:21:13	30.2	15	10.9	35	
05/23/2003 13:21:14	30.2	15	10.9	36	
05/23/2003 13:21:15	30.2	17	10.9	36	
05/23/2003 13:21:16	30.2	17	10.8	36	
05/23/2003 13:21:17	30.1	19	10.8	36	
05/23/2003 13:21:18	30.1	19	10.8	36	
05/23/2003 13:21:19	30.1	21	10.8	36	
05/23/2003 13:21:20	30.1	21	10.8	37	
05/23/2003 13:21:21	30.0	23	10.8	37	

## Remote Unit Registration

In order to carry out wireless communication, it is first necessary to connect the RTR-57U Unit to your computer and register it as the Base Unit. Next you must register RTR-51, 52, 52Pt, 53 and RVR-52A Units as Remote Units. To register Remote Units, you first create Groups and then register the Remotes to the designated Group. By registering Remotes into Groups, it not only makes management easy, but allows, via the Base Unit, to make setting changes and recording start settings by Group. It is also possible to create files of the Remote Unit Registration Info, which can be read by other RTR-57U Units.

## Adjustment

This function allows you to correct or adjust for errors in measurement values. The Data Logger will record only the adjusted value.

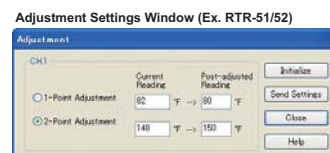

**Caution:** cannot guarantee that after carrying out adjustment the measuring accuracy will improve for all measuring ranges.

## Save as Text File Function

This function allows you to save data in Text File Format (CSV Format); in order to use the data with spreadsheet applications such as Excel and Lotus.



## View Current Readings via Browser

Via the browser it is possible to monitor the current readings of any Remote Unit that has been registered and view the recorded data in the Remote Unit in a simplified graph form. Up to 100 data readings from any one Remote Unit can be viewed with the RTR-5W.

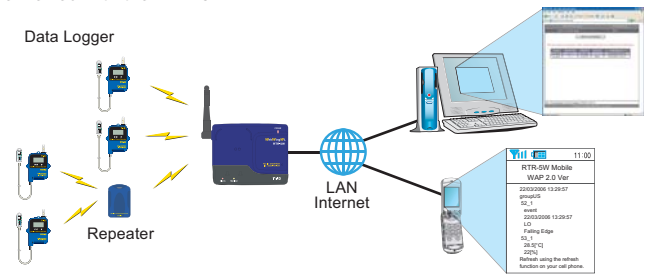

## Wireless Auto-downloading of Remote Unit Data

The RTR-5W is able to download via wireless communication the current readings and/or recorded data from any RTR-5 / RVR-5 Series Data Logger to your computer. Moreover, all settings for any RTR-5 / RVR-5 Series Unit can be carried out via a network.

## Effective Management of Multiple Remote Units

If there are multiple units, they can be divided into Groups for easy and effective management. Up to 64 groups (groups 1-64) can be registered.

**Note:** The possible number of Remote Units that can be registered into one RTR-5W is 64 units.

## Downloading Recorded Data over the Internet

The software included with the RTR-5W permits for the monitoring and viewing of current readings as well as gathering recorded data.

**Note:** In order to use this product via the Internet or cell phone you must first make necessary arrangements with a provider for a line and get a global IP address.

## Send Warning Report E-mails when a Warning Occurs

If a set upper or lower limit has been exceeded, a warning report E-mail can be sent to up to 5 mail addresses, including test message to cell phones.

# RTR-5W for Windows

The [RTR-5W for Windows] software has been designed to allow for the carrying out of various tasks such as network settings, downloading of recorded data and graph display of recorded data, as well as the management of Groups of Remote Units. [RTR-5W for Windows] is made up of 5 applications, complete with our Auto-Download feature that allows for the downloading of logged data at either a set interval or at a set time of day. [RTR-5W for Windows] (the main software) allows for the basic management of Groups of Remote Units, the monitoring of current readings and the settings for Remote Units. The [Network Settings Utility] facilitates the setting up of a network. With [Temperature/Humidity Graph], you can view downloaded recorded data in graph form and easily print graphs as displayed. Also included are [Multi-Scale Graph], which enables you to view various axes (different scales) in the same graph and [Event Viewer], which permits for the viewing and printing of event data for RVR-52A data files (\*.rp7).

## Software Included with RTR-5W

## Make Settings for PC Control via Network

Via a network, it is possible to make not only network settings in the RTR-5W, but also recording condition settings and warning settings as well. Even, if there are more than one RTR-5W connected to the network, it is easy to make settings by viewing the list in the Network Settings Utility and make all necessary settings.

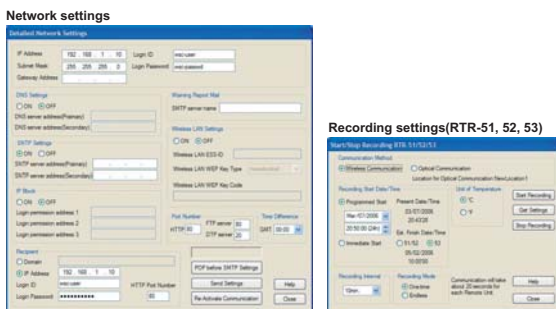

## Register and Make Settings for Remote Units

RTR-5W for Windows allows you to register any logger in the RTR-5 Series as a Remote Unit and carry out settings for that Remote.

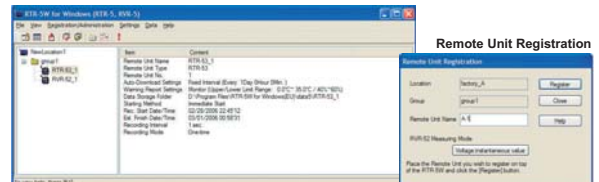

Also, if you wish to register multiple Remote Units, they can be divided into Groups for easy management.

## Repeater Registration

A "Repeater" is defined as an RTR-50 Wireless Communication Port that has been registered as a "Repeater" to act as a relay for Wireless Communication between a Base Unit and Remote Units from our RTR-5 Series.

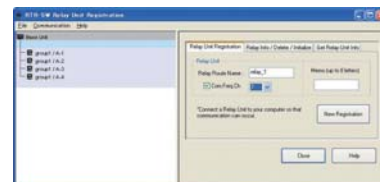

## Interpret Data in Graphs and Tables

Recorded data can be displayed in colorful, easy-to-interpret graphs and tables and analyzed by using Temperature/Humidity Graph and Multi-Scale Graph. Full use of the Windows interface makes the operation simple yet dramatic.

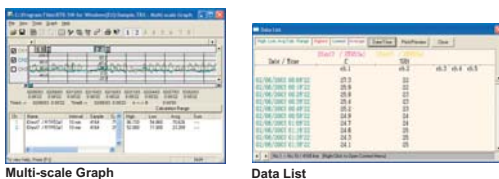

## Event Viewer

View event data recorded by RVR-52A in table form. You can further view info about the data in the viewer or print it out.

## Adjustment

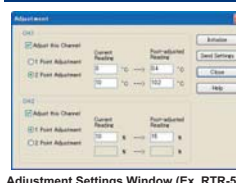

This function allows you to correct or adjust for errors in measurement values. The Data Logger will record only the adjusted value.

**Caution:** We cannot guarantee that after carrying out adjustment the measuring accuracy will improve for all measuring ranges.

## Export Data to be Saved or Printed

Recorded data can be easily saved into files or exported for printing. It is possible to convert the data for a specified range (time period) to common text file format, so that it can be exported to spreadsheet software such as Excel or Lotus.

**Note:** For Event Viewer it is not possible to select the range to be saved.

# Specifications

Unit Type	RTR-51/51L	RTR-52/52L	RTR-52Pt/52PtL	RTR-53/53L	RVR-52A/52AL
Measurement Item	Temperature	Temperature	Temperature	Temperature and Humidity	Voltage, Soil Moisture
Measurement Channel	1 Temperature Channel	1 Temperature Channel	1 Temperature Channel	1 Temp and 1 Humidity Channel	1 Channel
Measurement Range	-40 to 80°C	-60 to 155°C	-199.9 to 600°C	0 to 55°C, 10 to 95%RH	Voltage: 0 to 6.5V
Measurement Accuracy	Avg. ±0.5°C	Avg. ±0.3°C (-20 to 80°C) Avg. ±0.5°C (-40 to -20°C / 80 to 110°C) Avg. ±1.0°C (-60 to -40°C / 110 to 155°C)	±0.3°C (-199.9 to 80°C), ±0.5°C (80 to 450°C) ±1.0°C (450 to 600°C) (at 0 to 50°C / Sensor accuracy is not included.)	Avg. ±0.3°C ±5%RH (at 25°C and 50%RH)	±0.5% +5dgt. (at 0 to 40°C)
RTR-51 Internal Temp. Sensor Thermal Time Constant	15 minutes (L Type: 25 minutes)	—	—	—	—
RVR-52A Input Voltage Range	—	—	—	—	0 to 6.5V Lo: below 0.6V / Hi: above 2V(MAX: 30V)
Measurement Display Resolution	0.1°C	0.1°C	0.1°C	0.1°C · 1%RH	Vo: 1mV Moisture: 0.1% Pulse: 1 Count Ev: 1sec
Response Time	—	—	—	—	Pulse: 30Hz / Approx. 15msec or more (over 2.5V) Ev: 1 sec.
Recording Capacity	16,000 Readings (RTR-53:8000 × 2 Readings)				Voltage, Moisture, Pulse: 16000 Readings Event: 8000 Readings
Recording Interval	1,2,5,10,15,20,30 seconds / 1,2,5,10,15,20,30,60 minutes Total of 15 choices (Excluding Event data)				
Recording Mode	Endless (Overwrite oldest data when capacity is full), One-time (Stop recording when capacity is full)				
LCD Display Items	Current Readings, Recording Settings, Battery Life Warning, Over Measurement Range Warning, Unit of Measurement				
Power	Lithium Battery (LS14250 (SAFT)) × 1 / L Series (Large Capacity Battery Pack) Lithium Battery (LS26500) × 1*1 / AC Adaptor (sold separately) *2				
Battery Life	Approx. 6 months (Battery life depends on measurement environment, recording interval and battery performance)				
Communication Method	Wireless Communication / Optical Communication				
Wireless Method	FCC Part15 Section249 / IC RSS-210				
Dimensions	H 2.48in (62mm) × W 1.88in (47mm) × D 0.76in (19mm), (excluding protrusions / antenna length 20mm) / with Large Capacity Battery Pack: D 2 in (50mm)				
Weight	Approx. 56g (including 1 lithium battery) / with Large Capacity Battery Pack: Approx. 109g				
Temp. Resistance of Unit	Temperature: -30 to 80°C (Unit temp resistance and measurement range is -40 to 80°C but wireless communication cannot occur in an environment of less than -30°C.)				
Water Resistance	IP67 (immersion proof)	IP64 (rated for use in daily life)			
Standard Sensor / Adaptor	—	TR-5106 (length: Approx. 24 in (0.6m)) × 1	RTR-05PI (length: Approx. 40 in (1m)) × 1	TR-3310 (length: Approx. 40 in (1m)) × 1	—
Input Cable	—	—	—	—	RPR-7101 (length: Approx. 60 in (1.5m)) × 1
Accessories Included	Lithium Battery (LS14250 (SAFT)) × 1, Tube × 1, Strap × 1, User's Manual (Warranty) × 1				
Others	RTR-51/52/52Pt/53, RVR-52A: In order to download data via wireless communication, it is necessary to purchase either an RTR-57U, RTR-5W, and/or RTR-50 unit. RVR-52A: Possible to measure current with the RVR-5203 4-20mA Probe.				

Unit Type	RTR-50	RTR-57U	RTR-5W
Type	Wireless Communication Port	Data Collector	Wireless Base Station
Compatible Models	RTR-51/52/52Pt/53, RVR-52A	RTR-51/52/52Pt/53, RVR-52A, TR-51A/52/51S/52S, TR-71U/72U, VR-71	RTR-51/52/52Pt/53, RVR-52A, RTR-50 (For Repeater)
Functions	Wireless Communication: Download Data, Monitoring, Warning Monitoring, Start / Stop Recording, Wireless Repeater Function  Optical Communication: Download Data / Start / Stop Recording	Downloading data (possible to display results of upper and lower limit check after downloading) / Display Saved Data Graphs / Display Highest and Lowest Temperature / Set Recording Start for Remote Data Loggers / Delete stored data (one reading / all readings) / Monitor Current Temperature / Search for Remote Units Wave Check (10-level display of radio wave strength for each channel (0-21ch.))	Download recorded data from Data Loggers, Control data loggers devices, Network Connection Functions, Monitor current readings via browser, View recorded data in simplified graph form via browser
Recording Capacity	—	16,000 Readings × 16 = 256,000 Readings	—
Power	USB bus power, 2 AA batteries, AC Adaptor*2	2 AAA Alkaline Batteries (LR03), Can use rechargeable AAA Ni-Cd or Ni-MH 1.2V batteries, AC Adaptor*2	Specific AC Adaptor (AD-0605) Current Consumption: 300mA (when wired LAN is used)
Battery Life	6 Months of continued use on 2 AA alkaline batteries when used as Repeater for five minutes a day.	100 hrs under Continuous Operation	—
Data Backup	—	Approx. 1 year with switch off	—
Communication Method	For Data logger: Wireless Communication / Optical Communication (2400bps) For PC: USB Communication (Full speed) / Serial Communication (19200bps)	For Data logger: Wireless Communication / Optical Communication (2400bps) For PC: USB Communication (Full speed) / Serial Communication (19200bps)	For Data logger: Wireless Communication / Optical Communication (2400bps) For PC: LAN / Wireless LAN
Wireless Method	FCC Part15 Section249 / IC RSS-210	FCC Part15 Section249 / IC RSS-210	FCC Part15 Section249 / IC RSS-210
Dimensions	H 3.84in (96mm) × W 2.64in (66mm) × D 1in (25mm)	H 5in (125mm) × W 2.32in (58mm) × D 0.95in (24mm) (excluding protruding part)	H 3.32in (83mm) × W 4.08in (102mm) × D 1.12in (28mm) (excluding protrusions)
Weight	Approx. 2.12oz (60g) (Batteries not included)	Approx. 4.4oz (125g) (Including 2 AAA Alkaline batteries)	Approx. 4.79oz (135g)
Operating Conditions	Temperature: -10 to 60°C (-30 to 60°C when external powerconnected) Humidity: 20 to 80%RH (No condensation)	Temperature: 0 to 50°C Humidity: Less than 90%RH (Without dew condensation)	Temperature: 0 to 60°C Humidity: 20 to 80%RH (No condensation)
Accessories Included	User's Manual and Warranty × 1, Software (RTR-50 for Windows) × 1 USB Communication Cable × 1	User's Manual and Warranty × 1, Software (T&D Recorder for Windows) × 1 USB Communication Cable × 1, AAA Alkaline Batteries (LR03) × 2	User's Manual and Warranty × 1, Software (RTR-5W for Windows) × 1 AC Adaptor × 1, LAN cable × 1
Others	—	—	External Output (Warning Output) One point photo MOS relay contact 50V / 0.1A
Compatible OS	Windows 98SE / Me / 2000 / XP Vista English	Windows 98SE / Me / 2000 / XP / Vista English	Windows 2000 / XP / Vista English

\*1: T&D does not supply this battery. Contact your local authorized T&D sales representative.

\*2: Contact your local authorized T&D sales representative.

 **Caution regarding safety** For safe operation carefully read instructions before using this unit.

Colors in the photos in this catalog may be different from real product colors. The specification and designs of the products in this catalog are true as of December 2007. Specifications are subject to change without notice. Microsoft®, Windows®, and Excel® are registered trademarks of Microsoft Corporation USA and other countries. Company names and product names are trademarks or registered trademarks of each company. Teflon® is a registered trademark of the Dupont Corporation and of the Mitsui Dupont Fluoro-chemical Corporations. Lotus® is a registered trademark of the Lotus Development Corporation. Pentium® is a registered trademark of the Intel America Corporation.

## ■Distributor

J & S Instruments, Inc.  
3071 State Route 72 South  
Springfield, OH 45505-5023

Phone 937-325-7499

Fax 937-323-9588

sales@jsinstruments.com